

ZS-6216E
USB-DIO Unit

User's Manual

Ver.01



Zip Code: 183-0027

2-13-37, Honmachi, Fuchu, Tokyo, Japan

TEL: +81-(0)42-368-2126

FAX: +81-(0)42-364-0067

URL: <http://www.zenisu.co.jp>

◆ Table of contents ◆

1.Outline	3
2.Specification	3
2.1.Operating environment	3
2.2.USB	3
2.3.Product sprcification.....	4
2.4.Photo MOS relay.....	4
2.5.Photo coupler	4
2.6.Appearance	4
3.Install.....	5
3.1.Windows 7	5
3.2.Windows 10	7
3.3.Windows 8/8.1 (Without operation guarantee)	7
4.Operation.....	8
4.1.Outline of operation.....	8
4.2.I/O operation	9
4.3.Command table.....	9
4.3.1. R command.....	9
4.3.2. W command.....	10
4.3.3. O command (ON / OF command).....	10
5.Connector table	11
6.Warranty.....	11

1.Outline

ZS-6126E is a unit that built-in 8 photo MOS relays and 8 photo couplers.

It is possible to be controlling of I/O and doing level conversion by operating photo MOS relay and photo coupler with connecting PC having USB interface.

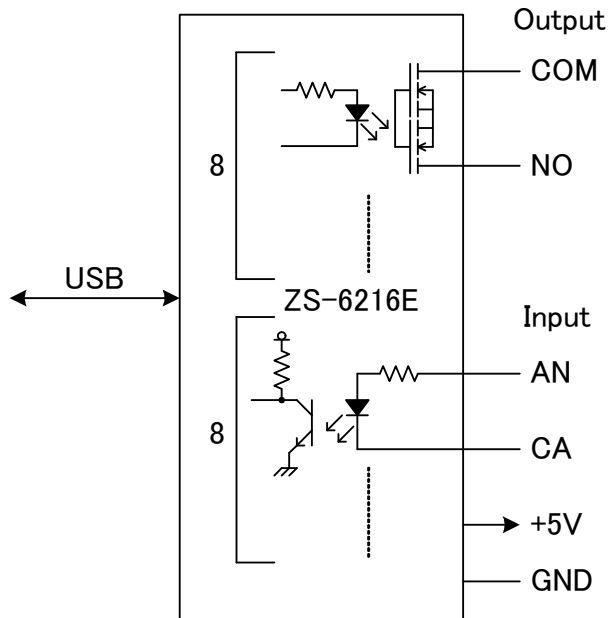

2.Specification

2.1.Operation environment

- PC : IBM PC/AT compatible machine (USB port is necessary)
- OS : Microsoft Windows 7, 10 ※Windows 8 / 8.1 (without operation guarantee)

2.2.USB

Compliant with USB2.0 standard.

2.3.Product specification

Model	ZS-6216E
USB connector	Micro USB2.0 micro-B (female)
Data connector	D-SUB 37 pin (female)
Power	USB bus power (DC4.75V to 5.25V 100mA 以下)
Environment of usage	Temperature 0°C to 50°C Hummidity85% or less
Storage temperature	-20°C to 80°C
Size	76(W) × 16(H) × 52(D) mm
Accessory	D-SUB 37 pin (male) x 1

2.4.Photo MOS relay

Relay	TLP3215 (Toshiba)
Contact resistance	1.5Ω or less
Related load	40V, 300mA
Operation time	500μs or less
Recovery time	500μs or less

2.5.Photo coupler

Photo coupler	PS2911-1-A/K (Renesas)
Input voltage	DC5V to DC24V

2.6.Appearance



Top view



USB connector side



Data connector side

3.Install

3.1.Windows 7

In order to use this product, it is necessary to install the device driver at first.

When it is connected to a computer, the following screen will be displayed.

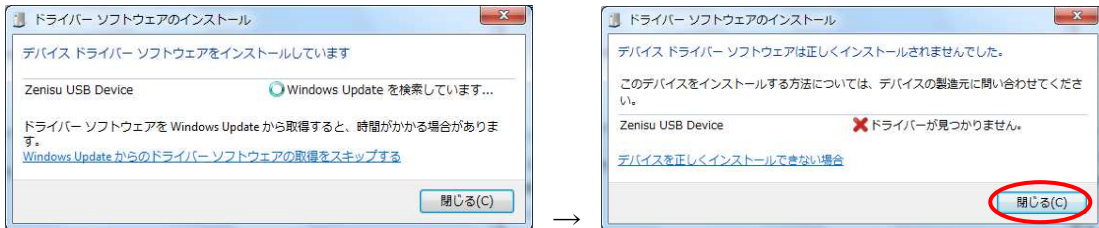

Click “close” button.

Open the device manager, and click “other device” and choose “Zenisu USB Device”.

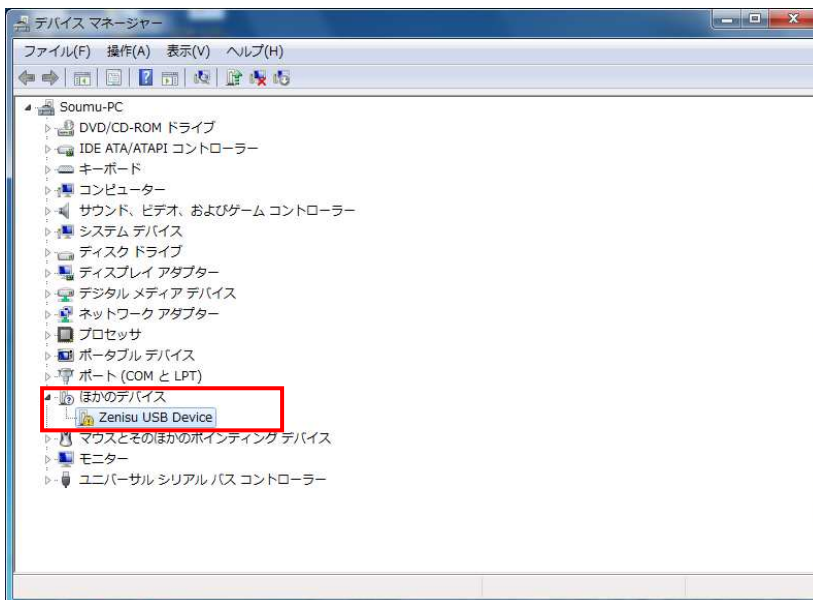

Click “driver update”.

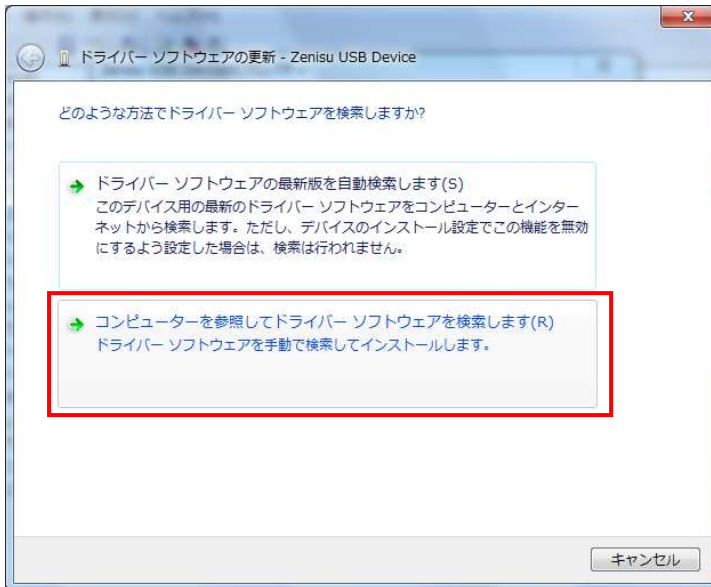

Click “Refer to the computer and search a driver software”.

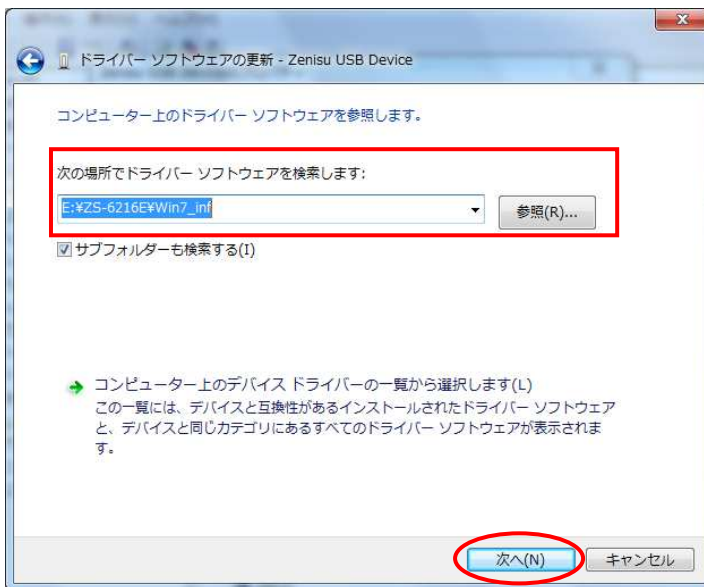

Specify “Win7_inf” and click “Next” button.

Installation starts automatically.

Click “Install this driver” if the following screen will be displayed.

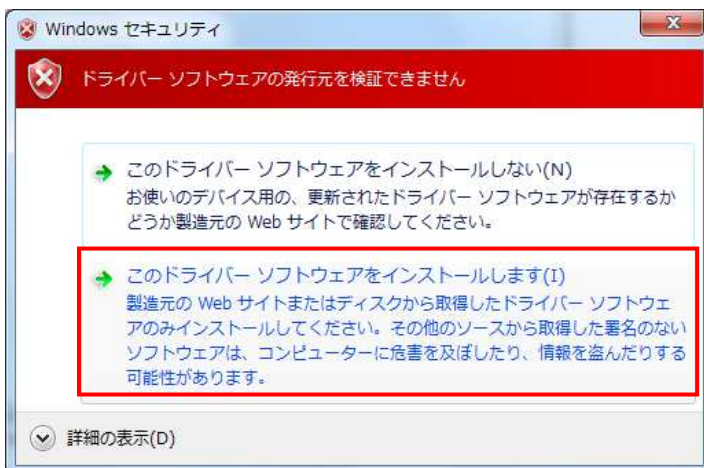

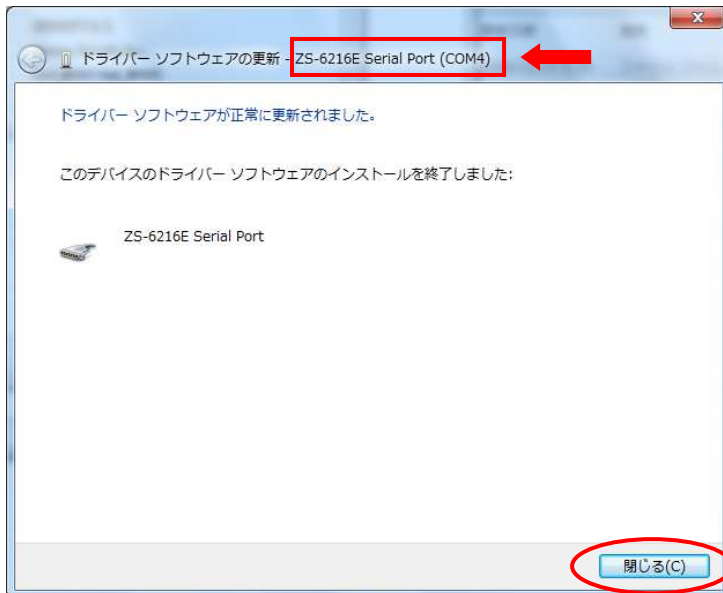

Install is completed. Please check the “COM port number” displayed on the top side.

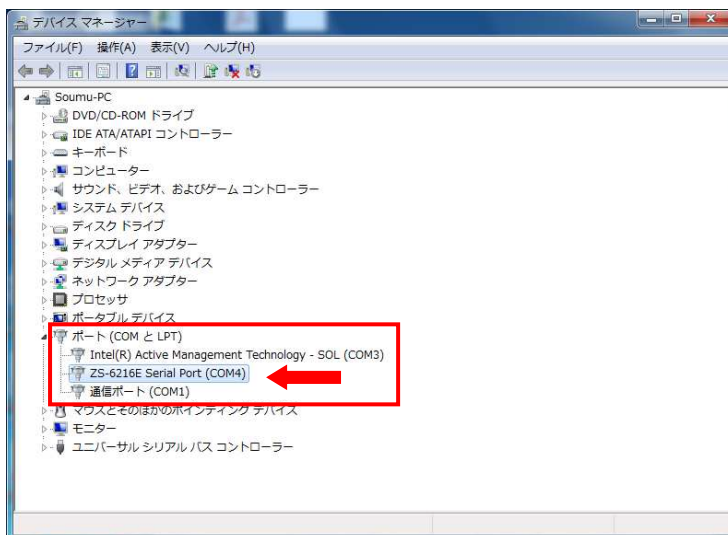

It is possible to confirm “COM port number” from the device manager too.

3.2.Windows 10

In case of Windows 10, installation starts automatically when connecting with computer.
It is possible to confirm “COM port number” from the device manager.

3.3.Windows 8/8.1 (Without operation guarantee)

In case of Windows 8 / 8.1, operation is not guarantee.

If disable driver signature of Windows 8, it is possible to install the device driver in the same way as Windows 7.

4.Operation

4.1.Operation outline

- ① ZS-6216E is recognized as COM port from the computer.

When it will be installed the device driver, “ZS-6216E Serial Port(COM x)” or “USB Serial device(COM x)” is displayed on the device manager.

Note) “x” is the number.

If you create a program, please create it according to the displayed COM number.

If it is difficult to confirm the port number, you can identify it by plugging in and pulling out the USB cable while displaying the device manager.

Please set as follows when setting the port open in the program.

- COM port number :The specified number by the device manager.
- Baud rate :9600bps It does not affect communication speed.
- Character length :8 bit
- Stop bit length :1 bit
- Parity bit :None
- Flow control :None

- ② Assignment table of data code

The data transfer method is ASCII code. 1 character will be converted to 4 bit binary code.

4 bit binary				USB data
8	4	2	1	HEX
0	0	0	0	0
0	0	0	1	1
0	0	1	0	2
0	0	1	1	3
0	1	0	0	4
0	1	0	1	5
0	1	1	0	6
0	1	1	1	7
1	0	0	0	8
1	0	0	1	9
1	0	1	0	A
1	0	1	1	B
1	1	0	0	C
1	1	0	1	D
1	1	1	0	E
1	1	1	1	F

4.2.I/O operation

① Output to the port

➤ Port output (1 byte)

It will set the data to the output port when the data is received from the computer by "W" command. It will return "OK" to the computer when the data will be set to the output port.

➤ Bit output

It will set the data to the specified bit when the data is received from the computer by "O" command. It will return "OK" to the computer when the data will be set to the specified bit.

② Input from the port

➤ Port input

When ZS-6216E will be received "R" command from the computer, capture the data from the input port and return it to the computer.

4.3.Command table

ZS-6216E recognizes the 1st byte of the data as the control command and control it.

It has to attach a delimiter (CR+LF) on the end of data when send the data.

It will be returned "NG" if the 1st byte of the data should not be as a command.

Command	Function
R	Read the data from the input port.
W	Write the data to the output port.
O (ON)	Specified bit on the output port will be "ON" (Hi).
O (OF)	Specified bit on the output port will be "OFF" (Low).

4.3.1. R command

➤ Function

Read the data from the input port. The return is 2 bytes, the order is high and low.

➤ Format

R CR LF

➤ Return value

xx CR LF : It will be received 2 bytes of input port data.
"x" is ASCII code from 0 to F.

NG CR LF : Recognition error of command or data.

➤ Example

Send : R CR LF

Reply : 01 CR LF (IN1 is ON , from IN2 to 8 are OFF)

4.3.2. W command

- Function
Write the data to the output port. The data is 2 bytes, the order is high and low.
- Format
Wxx CR LF : Write the output data following "W" to the output port.
"x" is ASCII code 0 to F.
- Return value
OK CR LF : Data output to the output port is complete.
NG CR LF : Recognition error of command or data.
- Example
Send : W01 CR LF
Reply : OK CR LF (OUT1 is ON, from OUT2 to 8 are OFF)

4.3.3. O command (ON / OF command)

- Function
Specified bit on the output port will be set "ON" or "OFF".
- Format
ONx CR LF : Write the specified bit number following "ON".
"x" is ASCII code 1 to 8.

OFx CR LF : Write the specified bit number following "OF".
"x" is ASCII code 1 to 8.
- Return value
OK CR LF : Data output to the output bit is complete.
NG CR LF : Recognition error of command or data.
- Example
Send : ON1 CR LF
Reply : OK CR LF (OUT1 is ON)

Send : OF2 CR LF
Reply : OK CR LF (OUT2 is OFF)

5.Connector table

Connector: DC-37S-NR (JAE)

Signal	Pin number	Signal
IN1(AN)	1	
	20	IN1(CA)
IN2(AN)	2	
	21	IN2(CA)
IN3(AN)	3	
	22	IN3(CA)
IN4(AN)	4	
	23	IN4(CA)
IN5(AN)	5	
	24	IN5(CA)
IN6(AN)	6	
	25	IN6(CA)
IN7(AN)	7	
	26	IN7(CA)
IN8(AN)	8	
	27	IN8(CA)
	9	
	28	
OUT1(COM)	10	
	29	OUT1(NO)
OUT2(COM)	11	
	30	OUT2(NO)
OUT3(COM)	12	
	31	OUT3(NO)
OUT4(COM)	13	
	32	OUT4(NO)
OUT5(COM)	14	
	33	OUT5(NO)
OUT6(COM)	15	
	34	OUT6(NO)
OUT7(COM)	16	
	35	OUT7(NO)
OUT8(COM)	17	
	36	OUT8(NO)
	18	
	37	GND
+5V	19	

Photo coupler

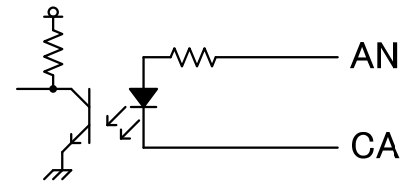
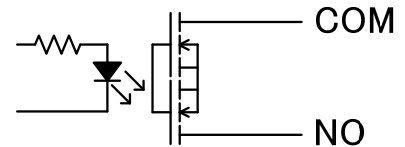

Photo MOS relay



6.Warranty

If it fails during normal use, we will repair it free of charge as described in this warranty as below.

- 1 During the warranty period which is one year from the date of purchase, we will repair it free of charge in case of malfunction in accordance with instruction manual.
- 2 It will be charged for extra in the following case, even during warranty period.
 - Incorrect usage or failure or damage caused by carelessness.
 - Failure or damage caused by improper repair or remodeling.
 - Failure or damage caused by external factors such as fire, earthquake, other natural disasters, abnormal voltage and so on.
 - Replacement of consumable parts.
 - Change of power supply and voltage.
- 3 This warranty provision is effective only in Japan.